

# INSTALLATION AND OPERATION GUIDE FOR **HARGROVE** GAS LOGS NATURAL GAS

**ADEQUATE FIREPLACE VENTILATION IS REQUIRED FOR SAFETY. GAS LOGS MUST BE INSTALLED BY PERSONNEL QUALIFIED FOR INSTALLING GAS APPLIANCES.**

## **NOTE !**

**READ INSTRUCTIONS FULLY BEFORE INSTALLING OR OPERATING. INSTALLERS LEAVE THESE INSTRUCTIONS WITH CONSUMER!**

Hargrove Manufacturing Corporation uses refractory material to create ceramic logs. Each log is hand finished to assure the most realistic, detailed log available. The gas log burner system is designed to burn like wood with a yellow smoky flame. For this reason the gas log set must be burned only in a fully vented, non-combustible fireplace with the **damper completely open** and the chimney free of any obstructions or restrictions. The fireplace must be designed and approved to burn wood. The minimum permanent, free opening provided by the fireplace chimney must be 8" in diameter (50 square inches)

**IT IS THE HOMEOWNERS RESPONSIBILITY TO ASSURE THEIR FIREPLACE HAS ADEQUATE DRAFT.**

The realistic yellow flame produces carbon monoxide and soot. Under normal conditions these products are exhausted up the chimney. If fumes or soot from the gas burning are evidenced in the room when the damper is fully open, it indicates that the fireplace draft is defective. Do not operate your gas log set until the fireplace draft is corrected. **ADEQUATE VENTILATION IS REQUIRED.**

**WARNING: IF THE INFORMATION IN THIS MANUAL IS NOT FOLLOWED EXACTLY, A FIRE OR EXPLOSION MAY RESULT CAUSING PROPERTY DAMAGE, PERSONAL INJURY OR LOSS OF LIFE.**

### **FOR YOUR SAFETY** IF YOU SMELL GAS:

1. OPEN WINDOWS
2. DON'T TOUCH ELECTRICAL SWITCHES
3. EXTINGUISH ANY OPEN FLAMES
4. IMMEDIATELY CALL YOUR GAS SUPPLIER

FLAMMABLE VAPORS MAY BE DRAWN BY AIR CURRENTS FROM OTHER AREAS OF YOUR HOUSE TO THIS APPLIANCE.

### **FOR YOUR SAFETY**

DO NOT STORE OR USE GASOLINE OR OTHER FLAMMABLE VAPORS AND LIQUIDS IN THE VICINITY OF THIS OR ANY OTHER APPLIANCE.

THE SIZE CHART BELOW INDICATES THE MINIMUM SIZE FIREPLACE OPENINGS IN WHICH DIFFERENT SIZE GAS LOG SETS CAN BE INSTALLED.

### **FIREPLACE SIZES**

GAS LOG SET SIZE	DEPTH	FRONT WIDTH
18	13"	22"
24	14"	28"



## GENERAL INFORMATION

**DO NOT USE A NATURAL GAS SET FOR PROPANE OR A PROPANE SET FOR NATURAL GAS. WHEN USING PROPANE (LPG) GAS AN AUTOMATIC PILOT SYSTEM MUST BE INSTALLED.**

1. There are many different local codes for gas fire logs. The installation of this set must conform with local codes or, in the absence of local codes, to the National Fuel Gas Code ANSI Z223.1 1999.
2. ***This log set is designed for use with Natural Gas.***
3. When glass fireplace doors are used, always operate gas log set with the doors fully open to allow for proper combustion air.
4. A fire screen must be in place when the log set is in use.
5. The appliance and its individual shut off valve must be disconnected from the gas supply piping system at test pressures in excess of 1/2 psig. The appliance must be isolated from the gas supply piping system by closing its individual manual shut off valve during any pressure testing of gas supply system at test pressures equal to or less than 1/2 psig.
6. Minimum inlet supply pressure for Natural Gas is 7" water column. Maximum inlet supply pressure for Natural Gas is 10 1/2" water column.
7. After burning, the logs become fragile and should not be handled. Knocking or rubbing logs can cause concrete to crumble and is not covered under the warranty.
8. Use a soft, dry paintbrush for periodic dusting of the gas fire logs. Special care must be taken to clean the Birch logs. Rubbing will remove soot but will also remove the white pigments.
9. ***Do not burn wood with this set***

**NOTE:** GAS LOGS MUST BE INSTALLED BY PERSONNEL QUALIFIED TO INSTALL GAS APPLIANCES.

## INSTALLING YOUR HARGROVE GAS LOGS

Remove all the parts from the shipping container. Your set includes the following parts...

<u>Number by Set</u>	<u>16"-21" Sets</u>	<u>24" Sets</u>	<u>28"-30" Sets</u>	<u>36" Sets</u>
1. Pedestal Gate	PG-16	PG-20	PG-25	PG-30
2. Ember Burner	EB-14	EB-18	EB-22	EB-26
3. Silica Sand	(1) SD-8	(1) SD-10	(1) SD-12	(2) SD-8
4. Fire Embers	EM	EM	EM	(2) EM
5. Safety Pilot Control (optional)	SPC/CPC	SPC/CPC	SPC/CPC	SPC/CPC
6. Aluminum Connector	AC-18	AC-18	AC-18	AC-18
7. Fire Logs		* Number of logs determined by set size		
8. Damper Stop (optional)	DS	DS	DS	DS
9. Volcanic Cinders	VC	VC	VC	(2) VC

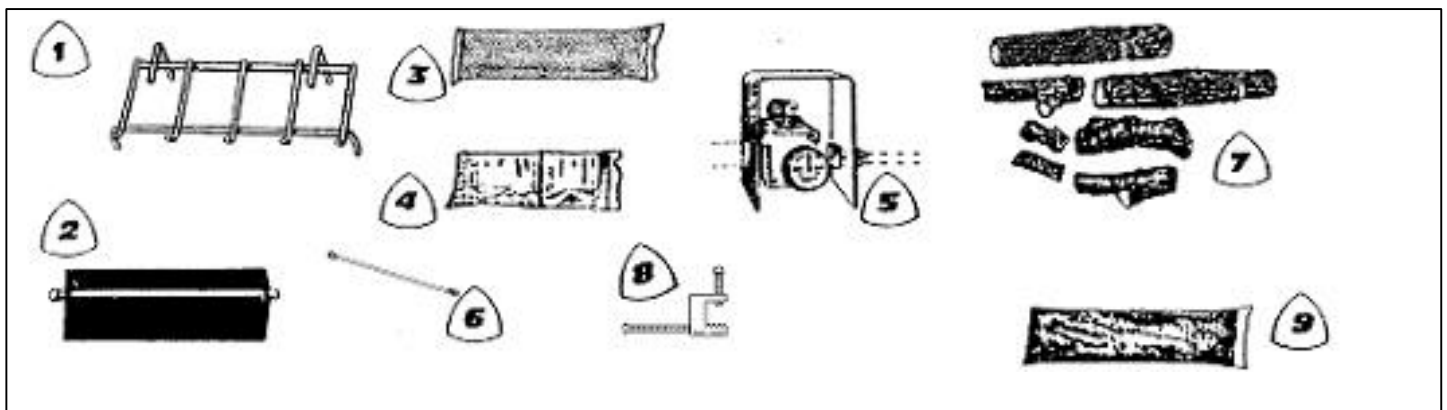

## DAMPER STOP

(optional)

Attach the damper stop clamp to the fireplace damper blade. Position the clamp to prevent full closure of the fireplace damper blade.

(See Figure 1)

If the damper stop provided does not fit, the installer shall install a permanent damper stop that will keep the damper open a minimum of 3".

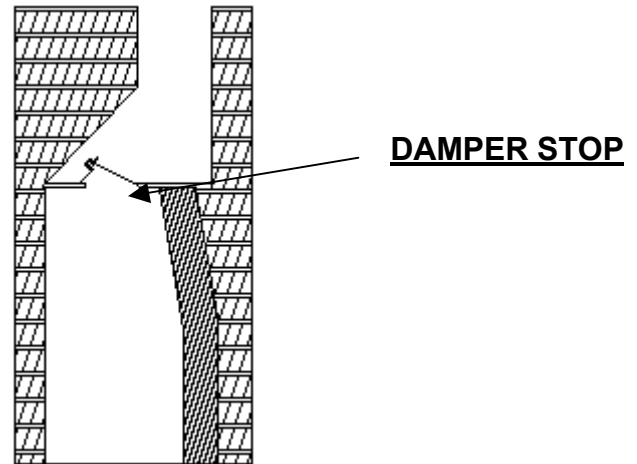

Figure 1

**\* CAUTION \***  
**THE DAMPER MUST BE FULLY OPEN WHEN  
OPERATING THE GAS LOGS!**

## EMBER BURNER POSITIONING

1. Turn gas **off**.
2. Remove old log lighter, ashes, and other material from the firebox.
3. Center the **ember burner** on the fireplace floor with the burner pipe completely visible from the front. For best results, the ember burner should be directly under the flue opening with a minimum of 4" from the front edge of the ember burner to the fireplace opening.
4. Place the **grate** over the ember burner so front legs of grate are just in front of ember burner pipe. Once the final positioning is established, mark the burner and grate position on the floor of the fireplace for reference points. Remove the grate and proceed with the gas connection.

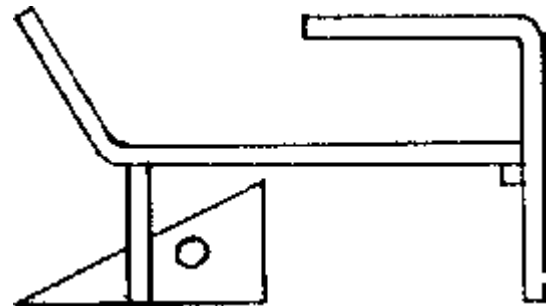

Figure 2

(See Figure 2.)

## GAS CONNECTION

1. The gas supply line should be 1/2" Inside Diameter (ID) up to 30 feet and 3/4" for longer distances.
2. Tighten the **black pipe cap** on the end of the burner pan pipe.
3. Use the **aluminum connector** to connect gas supply to the ember burner. When bending aluminum tubing use proper bending procedures to avoid kinking the tube. (If a safety pilot control is used follow instructions included for connecting gas to the pilot control.)
4. Check all connections for leaks using a soapy water solution.
5. Damper must remain fully open during operation. Place a lighted match next to the burner pipe. Do not hold the match in your hand while lighting the gas. Turn the gas supply on slowly until the gas ignites. Check the flame for even distribution, flame height and pressure. After checking the flame, turn off the fire. (To turn off the fire turn the gas valve off.) Do not close the damper until all the flames have died. Keep the glass doors fully open during all burning.

## BURNER PAN MEDIA

1. Fill the burner pan with **silica sand**. Sand level should be sloped evenly with the sides of ember burner. Place  $\frac{2}{3}$  of the **Part A Embers** on top of the sand. Burner should be completely full and level.
2. Light the gas and observe flame for even distribution.
3. **Part B Embers** (rockwool) are placed over the sand to simulate glowing embers. For best results pinch off pieces of the Part B material the size of a dime and feather it out. Place as much as desired over the area the gas comes through. (See Figure 3.)

Refer to the Pilot Control Lighting Instructions if installing a Safety Pilot Control inside or outside the fireplace.

## GRATE PLACEMENT

Place the **grate** over the ember burner using the reference marks made on fireplace floor earlier.

## LOG PLACEMENT

1. The longest log is the **front log**. It should be placed on the front of the grate with the flat, unfinished side facing the back. It is essential for this log to be positioned with the flat, unfinished side being straight up and down. (If the logs are laid flat on the grate the safety pilot control parts will over heat and shut the system off.)
2. The second longest log is the **back log**. It is positioned on the back pedestal of the grate with the flat side down.
3. The remaining logs are **top logs**. These logs are placed diagonally across the bottom logs and can be arranged to create the most realistic flame patterns. (See Figure 4.)

## VOLCANIC CINDERS

1. The black **volcanic cinders** are used to cover the fireplace floor, fittings and tubing around the burner system. Although not functional, the black cinders act as a picture frame to show off the glowing embers and yellow flame.
2. The remaining  $\frac{1}{3}$  **Part A Embers** can now be spread over the volcanic cinders to look like additional fallen ash under the logs.

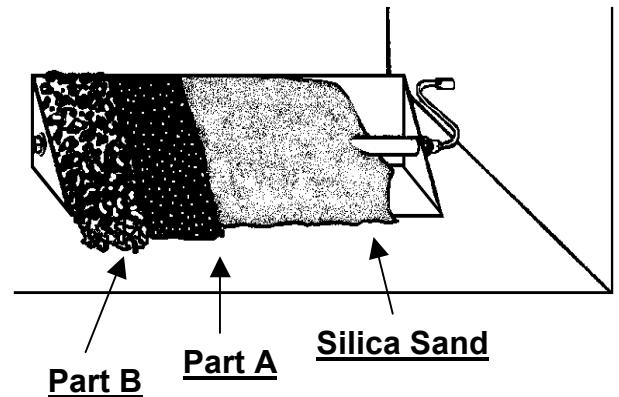

Figure 3

## SIDE VIEW OF LOG PLACEMENT

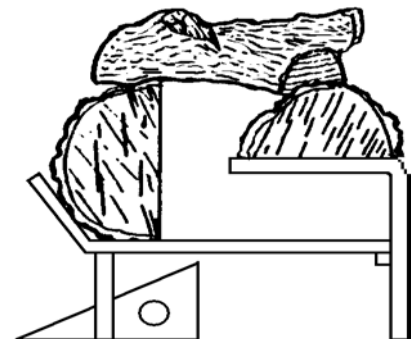

Figure 4

## FOR YOUR SAFETY

Do not use this appliance if any part has been under water. Immediately call a qualified service technician to inspect the appliance and to replace any part of the system or gas control which has been under water.

Keep this appliance clear and free from combustible materials, gasoline, and other flammable vapors and liquids.

# HARGROVE GAS

## LOGS

### CONCENTRIC VALVE (CPE-PO)

### PILOT CONTROL SYSTEM

### INSTALLATION INSTRUCTIONS

This gas pilot safety valve provides 100% shut-off of both pilot and main burner gas supply in the event of pilot flame failure. This valve is equipped with a manual gas control knob to provide for pilot lighting. It also has a control knob that controls flame height.

If the pilot flame goes out during normal operation, or if there is insufficient pilot flame to provide proper thermocouple output, the safety valve will close, stopping the flow of all gas. This valve is designed for use on all domestic heating gases up to 1/2" PSI.

#### FOR YOUR SAFETY

**IF YOU SMELL GAS:**

- 1. OPEN WINDOWS**
- 2. DON'T TOUCH ELECTRICAL SWITCHES**
- 3. EXTINGUISH ALL OPEN FLAMES**
- 4. IMMEDIATELY CALL YOUR GAS SUPPLIER**



#### CAUTIONS

- 1. This valve should be installed only by an experienced service technician trained in gas safety equipment.**
- 2. Turn off gas supply before installing valve.**
- 3. All piping must meet applicable local codes and ordinances and the national fuel gas code (ANSI Z223.1/NFPA NO. 54)**
- 4. All wiring must meet applicable electrical codes and ordinances.**
- 5. Check out the complete system after installing the valve.**
- 6. Prior to installation, verify conformance with burner manufacturer's installation instructions.**
- 7. Make sure all piping is free of foreign matter.**

**FLAMMABLE VAPORS MAY BE DRAWN BY AIR CURRENTS FROM OTHER AREAS OF YOUR HOUSE TO THIS APPLIANCE.**

#### FOR YOUR SAFETY

**DO NOT STORE OR USE GASOLINE OR OTHER FLAMMABLE VAPORS AND LIQUIDS IN THE VICINITY OF THIS OR ANY OTHER APPLIANCE.**

# INSTALLATION INSTRUCTIONS

## **! WARNING !**

**Fire hazard. Do not disassemble or attempt repair of this unit. Disassembly, reassembly or internal adjustment could cause valve to malfunction, resulting in personal injury, death or property damage. If the control valve does not operate properly following installation or service, replace the unit.**

**WARNING:** Valves may not shut off if flow is not in direction of arrow on valve body.

**WARNING:** Warranty is void if the CPC-C is installed behind the burner pan in the fireplace. (Fig.1)

### Parts List (Fig.2):

1. (CPC-C) Concentric Safety Gas Valve
2. (HS-CPC-250) Concentric Heat Shield w/Fiberglass Mat
3. (RSTPB-18) Thermocouple & Pilot Burner Assembly
4. (SC-3) Stainless Steel Extension Connector
5. (48-6) Brass Union
6. (50-6-6) 3/8 FIP X 3/8 FL
7. (N-6X1.5) 3/8 X 1 1/2 Black Nipple

**Fig.1 DO NOT INSTALL CPC-C BEHIND THE EMBER BURNER PAN IN THE FIREPLACE. CPC-C MAY OVERHEAT.**

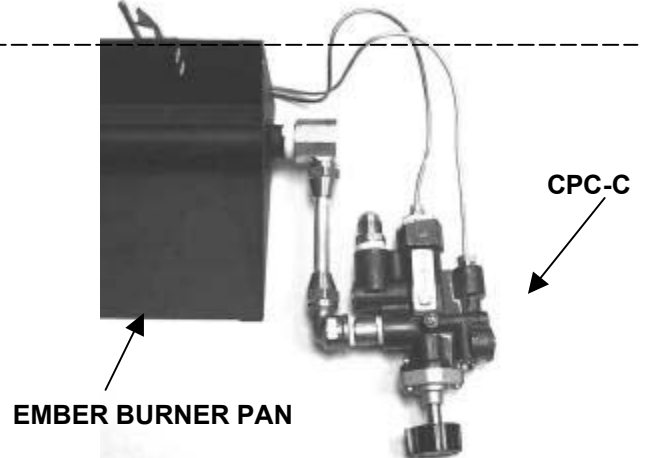

**Note:** Piping from gas supply to valve and from valve to burner must be supplied by installer when installed outside the firebox.

**Fig.2**

### Parts Included In CPE-PO Kit

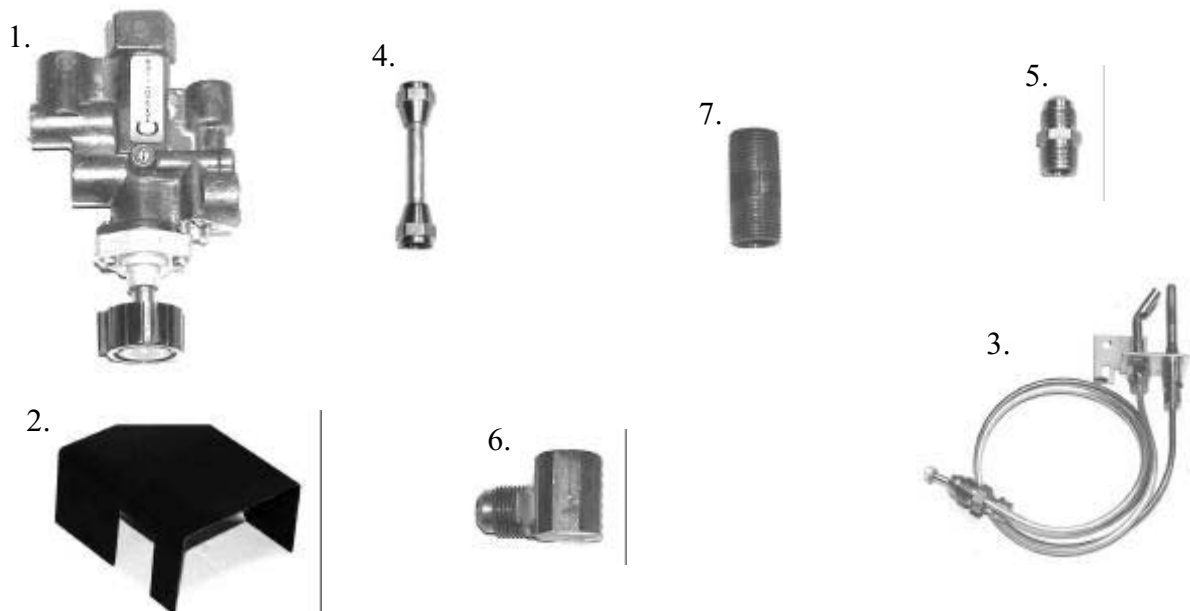

# INSTALLATION INSTRUCTIONS

This gas valve should be installed according to the following instructions. Check for gas leaks with a soap solution after completing installation.

## MAIN PIPING CONNECTIONS

1) Be sure the main gas supply is shut off before starting the installation. It should be located so that the gas control knob is easily accessible.

2) Direction of gas flow is indicated by the directional arrow on the outlet boss.

3) You should use new pipe, which has properly chamfered and reamed. If you use old pipe, be sure it is clean and free of rust, scale, burrs, chips and old pipe joint compound.

4) Apply pipe joint compound (pipe dope) that is approved for all gases, only to the male threads of pipe joints. DO NOT apply compound to first two threads. Do not thread pipe too far.

NOTE: Applying pipe joint compound to pipe threads will prevent chips from passing into internal valve parts, since the pipe joint compound will collect and retain chips that are formed as the pipe is threaded into the body.

5) If a vise or open-ended wrench is used to hold the control while installing piping, do not tighten excessively, as this may damage the control.

## CPC INSTALLATION

See Fig. 3

1) Attach the Brass 50-6-8 (in accessory kit parts packet) to the pipe extending out of the Ember Burner pan. Make sure the flared end of the 50-6-8 is facing toward the front of the Ember Burner Pan.

2) Connect the 50-6-6 brass elbow to the N-6X1.5 black nipple.

3) Attach the black nipple from step 2 into the outlet on the CPC-C.

4) Attach the 48-6 brass to the inlet (opposite of the control knob) side of the CPC-C.

5) Use the SC-3 extension connector to attach the 50-6-8 and the 50-6-6.

6) Use the #8X1/2 screws (not shown) to attach the RSTPB-18 pilot assembly to the back side of the burner pan in the pre drilled holes. Attach the pilot so that the pilot burner is above the back wall of the burner pan.

## Pilot Gas Connection

Install the silver tubing from the RSTPB-18 into the pilot gas tapping, turning until finger-tight. Slowly tighten the fitting until a slight "give" is felt. Then tighten an additional 1 1/2 turns.

## Thermocouple Connection

The thermocouple connector should be clean for good electrical contact. Run the thermocouple nut into the thermocouple connection as far as possible by hand. Then set the nut with 1/4 to 1/2 additional turn

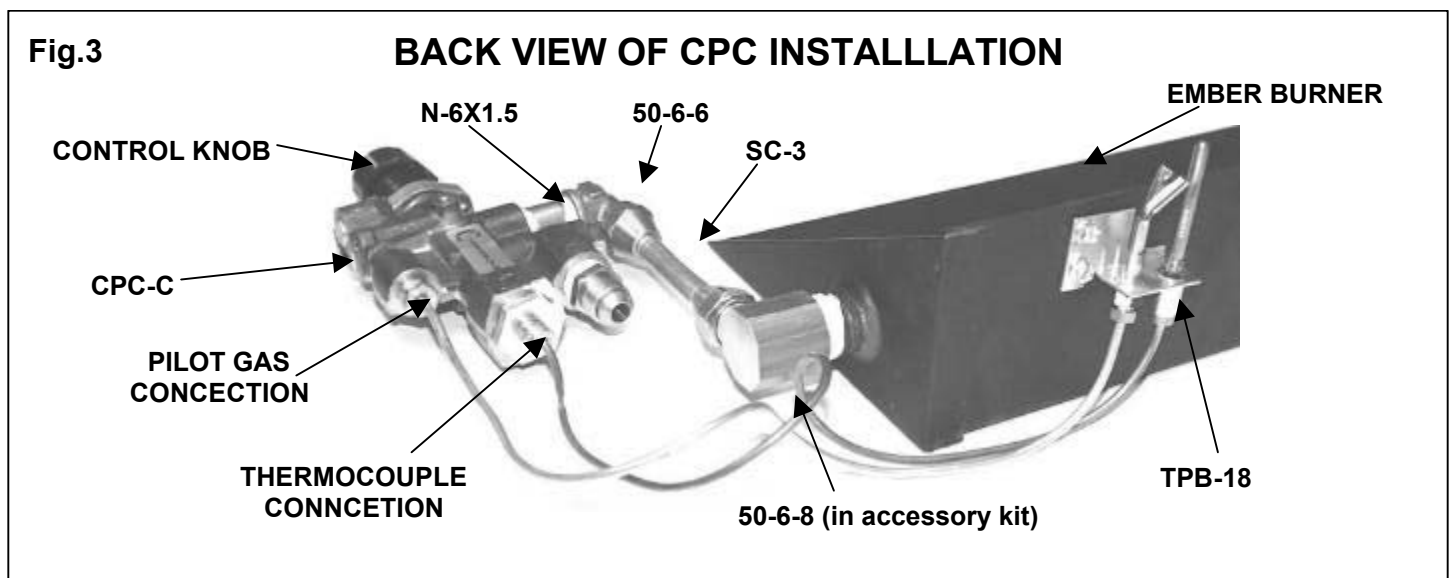

# LIGHTING INSTRUCTIONS

## FOR YOUR SAFETY READ BEFORE LIGHTING

**WARNING: If you do not follow these instructions exactly, a fire or explosion may result causing property damage, personal injury or loss of life.**

A. This appliance has a pilot, which must be lit by hand. When lighting the pilot, follow these instructions exactly.

B. Before lighting smell all around the appliance area for gas. Be sure to smell next to the floor because some gas is heavier than air and will settle on the floor.

### **FOR YOUR SAFETY**

#### **"What to do if you smell gas"**

- \* **Do not try to light any appliance.**
- \* **Do not touch any electrical switch; do not use any phone in your building.**
- \* **Immediately call your gas supplier from a neighbor's phone. Follow the gas supplier's instructions.**
- \* **If you cannot reach your gas supplier, call the fire department.**

C. Use only your hand to push in or turn the gas control knob. Never use tools. If the knob will not push in or turn by hand, don't try to repair it. Call a qualified service technician. Forced or attempted repair may result in a fire or explosion.

D. **Do not** use this appliance if any part has been under water. Immediately call a qualified service technician to inspect the appliance and to replace any part of the control system and any gas control which has been under water.

### **PILOT LIGHTING PROCEDURE**

1. Turn the gas control knob to the *off* position (it will be necessary to depress the knob slightly at the *pilot* position). Allow five minutes for any gas in the combustion chamber to escape (LP gas, which is heavier than air, may require forced ventilation).

2. Turn the gas control knob to the *pilot* position.

3. Push in on the gas control knob and light the pilot immediately. Hold the knob down for one full minute after lighting the pilot.

4. When the gas control knob is released, the pilot flame should continue to burn (if the pilot goes out, repeat the above steps).

5. Rotate the gas control knob from *pilot* to *on* position (full counterclockwise position) to supply full flow of gas to main burner.

6. You can adjust the flame height by the control knob, if you turn it back towards the *pilot position* you will *decrease* the gas flow, in turn you will decrease the flame height.

### **PILOT FLAME ADJUSTMENT**

These controls are factory preset and will not normally require additional adjustment of the pilot flame. If field adjustment of the pilot flame is required, turn the adjusting screw clockwise reduce flame, or counterclockwise to increase flame.

# HARGROVE MANUFACTURING CORPORATION

## SAFETY PILOT CONTROL TROUBLE SHOOTING GUIDE

### POSSIBLE CAUSES:

### CORRECTIVE ACTIONS

#### 1) Nature of Trouble: Pilot light won't light.

- |                     |  |
|---------------------|--|
| 1a) Gas supply off. | 1a) Turn gas supply on.  |
| 1b) Air in line.    | 1b) Bleed gas through ember burner until all the air is out of the line. Bleeding through the pilot burner is not effective. |
| 1c) Kink in line.   | 1c) Straighten the tubing and assure there are no cracks in the tubing, or replace the tubing.                               |

#### 2) Nature of Trouble: Pilot light won't stay lit after releasing knob.

- |   |  |
|---|--|
| 2a) Line from thermocouple is not making good contact with valve.                         | 2a) Tighten fitting that connects thermocouple line to the pilot control valve.  |
| 2b) Pilot light flame is too strong and blows itself out.                                 | 2b) Adjust the flame on the pilot burner in accordance with the pilot control instructions, or replace the pilot orifice with a larger orifice.  |
| 2c) Pilot light flame is too low and does not transmit enough electricity to pilot valve. | 2c) Adjust the flame on the pilot burner in accordance with the pilot control instructions, or replace the pilot orifice with a larger one.  |
| 2d) Pilot light flame hits thermocouple too close to cold junction.                       | 2d) A cold junction is located on the lower 1/3 of the thermocouple. The pilot light flame must hit only the top 1/4 of the thermocouple or the cold junction will overheat and shut the system off. |
| 2e) Bad thermocouple.   | 2e) Replace the thermocouple. This is unlikely on a new set as all thermocouples have been factory tested before shipping.   |

#### 3) Nature of Trouble: Pilot light goes out after being lit.

- |   |  |
|---|--|
| 3a) Down drafts blowing out flame.  | 3a) Correct chimney down draft problems.   |
| 3b) Pilot light flame is too strong and blows itself out.                                 | 3b) Adjust the flame on the pilot burner in accordance with the pilot control instructions, or replace the pilot orifice with a larger orifice.  |
| 3c) Pilot light flame is too low and does not transmit enough electricity to pilot valve. | 3c) Adjust the flame on the pilot burner in accordance with the pilot control instructions, or replace the pilot orifice with a larger one.  |
| 3d) Pilot light flame hits thermocouple too close to cold junction.                       | 3d) A cold junction is located on the lower 1/3 of the thermocouple. The pilot light flame must hit only the top 1/4 of the thermocouple or the cold junction will over heat and shut the system down. |

#### 4) Nature of Trouble: Pilot light is noisy.

- |                                      |   |
|--------------------------------------|---|
| 4a) Pilot light flame is too strong. | 4a) Adjust the flame on the pilot burner in accordance with the pilot control instructions, or replace the pilot orifice with a larger orifice. |
|--------------------------------------|---|

## **5) Nature of Trouble: Pilot light goes out when ember burner is turned on.**

5a) Ember burner robs gas from line feeding the pilot light.

5a) Turn gas to ember burner on slower.

5a) Replace orifice adapter to ember burner with an orifice adapter with a smaller opening. NOTE: This will reduce the amount of flame on logs.

## **6) Nature of Trouble: Delayed ignition of ember burner. (Gas should ignite in 4 seconds.)**

6a) Gas is not getting to pilot light quick enough.

6a) Clear passageway through sand to allow easier and quicker access for gas from ember burner to pilot light.

6b) Incorrect locations or direction of pilot light.

6b) Assure pilot light directs flame over ember burner pan as well as properly hitting the thermocouple.

## **7) Nature of Trouble: System shuts down after burning 0-5 minutes. Cold junction on thermocouple has overheated.**

7a) Immediate over heating of the cold junction on the thermocouple.

7a) Assure thermocouple and pilot burner assembly are mounted on the back side of the ember burner pan per safety pilot control instructions. Assure the assembly is free from contact with silica sand or other materials.

7a) Check for leaks resulting in improper flame hitting the thermocouple.

## **8) Nature of Trouble: System shuts down after burning more than 5 minutes. Cold junction on thermocouple has overheated.**

8a) Front log positioned over thermocouple reflecting flame and heat onto thermocouple.

8a) If front log is laying flat, position the log on its edge such that the flat side is facing the back of the fireplace.

8b) Thermocouple knocked out of position or interfered with by grate.

8b) Reassemble thermocouple in its assembly and move the grate so that it will not interfere with thermocouple.

8c) Heating of thermocouple copper tubing via flame, contact with ember burner pan, grate or other materials.

8c) Assure copper tubing is not touching any materials and is routed approximately one inch off the fireplace floor and has a minimum of 1/2" air space surrounding the tubing.

8d) The firebox retains too much heat.

8d) If your fireplace has glass doors they must remain fully open. Make sure the damper is completely open during burning. Do not install safety pilot controls in stoves.

8e) Down drafts blowing flame on thermocouple.

8e) Correct down draft problems.

## **9) Nature of Trouble: Pilot valve will not shut gas off.**

9a) Pilot valve has overheated possibly components and/or seals.

9a) Shield from heat, or move valve out of firebox. Assure not gaskets or seals have been damaged and causing leaks. Turn off gas at a secondary shut off. Correct reason for overheating and replace valve.

## LIMITED WARRANTY

### Refractory Logs

Hargrove gas logs carry a limited lifetime warranty against any manufactured defect or breakage when installed indoors. A replacement will be available from the dealer at which the appliance was purchased. This warranty does not cover breakage caused by excessive handling once installed and fired. Outdoor applications carry a one (1) year limited warranty.

### Burner & Grate

If the burner or grate fails due to deterioration within two (2) years of the verified purchase date, a free replacement will be made available from the dealer at which the appliance was purchased.

### Valves, Remote Controls, & Switching Devices

Hargrove warrants all valves, remote controls and switching devices against manufacturing defects, which appear within two (2) years of the verified purchase date. Warranty does not cover products that have been damaged by misuse from overheating. Before any product is returned a Return Goods Authorization number (RGA) must be issued by Hargrove's Customer Service Department. All returns must be accompanied by an explanation of the problem and all necessary parts.

### All Other Parts

If any assembled part should fail to operate or be found defective which appear within two (2) years of the verified purchase date, a replacement will be available from the dealer at which the appliance was purchased.

Buyer shall notify Hargrove Mfg Corp. of any defect covered by this warranty no later than thirty (30) days after defect is discovered. Failure to provide notice within thirty (30) days shall void the limited warranty.

## WHAT IS NOT COVERED

1. Removal and reinstallation costs.
2. Labor costs for replacement or repairs.
3. Transportation or shipping cost.
4. The cost of a service call to diagnose trouble.
5. Painted Surfaces.
6. Damage or defect caused by improper installation, accident, misuse, abuse, alteration, or authorized service technician.
7. Replacement of burner or combustion chamber resulting from improper storage of the appliance.

## LIMITATIONS AND EXCLUSIONS

1. No one has authority to add to or vary this limited warranty, or to create for Hargrove Manufacturing Corporation any other obligation or liability in connection with this appliance.
2. Any implied warranty applicable to this appliance is limited in duration to the same period of time as this written Warranty. Some states do not allow limitations on how long an implied warranty lasts, so the above limitations may not apply to you.
3. HARGROVE MANUFACTURING CORPORATION WILL NOT BE LIABLE FOR INCIDENTAL, CONSEQUENTIAL, SPECIAL OR CONTINGENT DAMAGES YOU MIGHT SUFFER AS A RESULT OF A CLAIM UNDER THIS WRITTEN WARRANTY OR ANY IMPLIED WARRANTY. Some states do not allow the exclusion or limitation of incidental or consequential damages, so the above limitations or exclusion may not apply to you.
4. This warranty applies only to the original purchaser and may not be transferred or assigned.
5. If you cannot verify the purchase date of the appliance, the warranty period will begin on the date of which the appliance was manufactured.
6. Replacement or repair parts are warranted for the remaining period of the original part warranty. Warranty parts must be obtained through authorized dealers of this product who will provide original factory replacement parts. Failure to use original factory replacement parts voids this warranty.
7. The maximum liability of Hargrove Mfg Corp. in connection with this limited warranty shall not in any case exceed the contract price paid for the product claimed to be defective or unsuitable.
8. Purchaser or user agrees to hold Hargrove Mfg Corp. harmless from any and all claims by the buyer as a result of injury or damage to an ultimate user or other person caused by the product sold herein by the seller to the buyer, whether the injury or damage results from the assembly, installation, operation, shipment, storage, or manufacture of this product. Hargrove Mfg Corp. makes no warranties, expressed or implied, other than those expressly stated herein.

## YOUR DUTIES

This appliance must be installed by a qualified installer, operated and maintained in accordance with all applicable codes and the instructions furnished with the appliance. You must provide a receipt verifying the purchase date of the appliance when making a warranty claim with the dealer from which the appliance was purchased.

This warranty gives you specific legal rights, and you may also have other rights, which vary from state to state.

**To register your Hargrove product, please visit our website at <http://www.hargrovegaslogs.com/reg.htm>.**

**CONTACT INFO: Hargrove Manufacturing Corp.**

**Tele: (800) 725-4166**