



HARGROVE

Single Burner

Vent Free Room Heater

Millivolt / Split System

Operation and Installation Guide

READ AND SAVE THESE INSTRUCTIONS

Natural Gas
and
Propane (LP)
Models

member

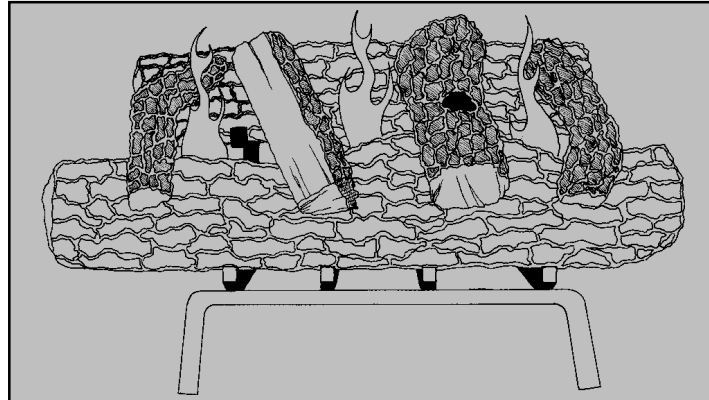

This appliance is designed to supplement a current heating system. It is not designed to be used as a primary heat source.

This appliance operates as an unvented room heater when fitted to a solid fuel burning masonry or factory built fireplace **with the flue damper closed**. It may also be installed in an approved unvented fireplace (approved models listed on page 1 in installation guide).

WARNING: THIS IS AN UNVENTED GAS-FIRED HEATER. IT USES AIR (OXYGEN) FROM THE ROOM IN WHICH IT IS INSTALLED. PROVISIONS FOR ADEQUATE COMBUSTION AND VENTILATION AIR MUST BE PROVIDED. REFER TO NATIONAL FUEL GAS CODE, ANSI Z223.1. REFER TO PAGE 2 OF THE INSTALLATION INSTRUCTIONS.

WARNING: Improper installation, adjustments, service, or maintenance can cause personal injury or property damage. Refer to this manual. For assistance or for additional information, consult a qualified installer, service agency or the gas supplier.

This appliance is only for use with the type of gas indicated on the rating plate. This appliance is not convertible for use with other gases.

WARNING: If information in this manual is not followed exactly, a fire or explosion may result causing property damage, personal injury or loss of life.

- Do not store or use gasoline or other flammable vapors and liquids in the vicinity of this or any other appliance.

-WHAT TO DO IF YOU SMELL GAS

- * Do not try to light any appliance.
 - * Do not touch any electrical switch; do not use any phone in your building.
 - * Immediately call your gas supplier from a neighbor's phone. Follow the gas supplier's instructions.
 - * If you cannot reach your gas supplier, call the fire department.
- Installation and service must be performed by a qualified installer, service agency or the gas supplier.

CONTENTS

PAGE

<i>PRE-INSTALLATION REQUIREMENTS</i>	1-2
Approved Fireplace Listings	1
Fireplace Location	1
Combustion & Ventilation Air Requirement Worksheet	2
<i>INSTALLATION SPECIFICATIONS</i>	3-5
BTU Ratings & Pressure Requirements	3
Fireplace Dimensions & Clearances	3
Minimum Clearances to Combustible Materials	4
Mantle Clearances	4-5
<i>INSTALLATION</i>	5-9
Fireplace Preparation	5
Gas Line Hook-Up	6
Wiring Schematic	7
Gas Pressure Check	7
Log Placement	8
Volcanic Cinder	9
Optional Pedestal Grate Facing	9
<i>OPERATION</i>	10-11
Lighting Instructions	10
Controlling Heat Output	11
Important Safeguards	11
Cleaning & Servicing	11
<i>PARTS IDENTIFICATION</i>	12
<i>ASSEMBLY IDENTIFICATION</i>	13
<i>TROUBLE-SHOOTING</i>	14-15
<i>LIMITED WARRANTY</i>	16

PRE-INSTALLATION REQUIREMENTS

Approved Fireplaces

This appliance operates as an unvented room heater certified under ANSI Z.21.11.2a-1997 when fitted to a masonry or factory built fireplace with the flue damper open or closed. It may also be installed in an approved ventless firebox that is certified to accept any certified log sets. The certified ventless firebox must meet the minimum dimensions required by the log sets. This appliance is also tested to the vented decorative appliance standard ANSI Z21.60.

WARNING: THIS APPLIANCE IS FOR INSTALLATION ONLY IN A SOLID-FUEL BURNING FIREPLACE OR APPROVED VENTLESS FIREBOX ENCLOSURE.

Fireplace Location

IMPORTANT: If installing in an approved vent free firebox, refer to their instruction guide for proper installation.

WARNING: DO NOT INSTALL THIS APPLIANCE IN ANY AREA WHERE GASOLINE OR ANY COMBUSTIBLE OR EXPLOSIVE MATERIAL WILL BE USED OR STORED. THE FLAME IN THIS APPLIANCE IS NOT ISOLATED FROM THE AIR SPACE IT HEATS AND IT WILL IGNITE FLAMMABLE VAPORS, DUST PARTICLES OR OTHER COMBUSTIBLE MATERIALS THAT COME IN CONTACT WITH IT WHICH CAN RESULT IN AN EXPLOSION OR FIRE.

To determine the safest and most efficient location for your Vent Free Fireplace, you must take into consideration the following guidelines:

1. The location must allow for proper clearances for accessibility of servicing and proper operation (see section on Fireplace Clearances - page 4).
2. Consider a location where heat output would not be affected by drafts, air conditioning ducts, windows or doors.
3. Inspect area surrounding the location chosen for the fireplace for possible air drafts that may effect the flames and possibly cause sooting. Air drafts may be caused by a ceiling fan near the fireplace, a hot furnace register, or an open door.

WARNING: DO NOT ALLOW FANS TO BLOW DIRECTLY INTO THE FIREPLACE. AVOID ANY DRAFTS THAT ALTER BURNER FLAME PATTERNS.

4. Due to high temperatures, the appliance should be located out of traffic and away from furniture and draperies. Young children should be carefully supervised when they are in the same room with the appliance.
5. Children and adults should be alerted to the hazard of high surface temperatures and should stay away to avoid burns or clothing ignition.
6. Install in an area providing adequate combustion and ventilation air (see section on adequate combustion and ventilation air requirements - page 2).
7. Do not install in a building that is of unusually tight construction. Unusually tight construction is defined as construction where:
 - a. Walls and ceilings exposed to the outside atmosphere have a continuous water vapor retarder with a rating of 1 perm or less with openings gasketed or sealed, and
 - b. Weather stripping has been added on openable windows and doors, and
 - c. Caulking or sealants are applied to areas such as joints around window and door frames, between sole plates and floors, between wall-ceiling joints, between wall panels, at penetrations for plumbing, electrical, and gas lines, and at other openings.
8. Do not install this heater in bedrooms, bathrooms, or recreational vehicles.
9. This appliance may be installed in an aftermarket* manufactured (mobile) home, where not prohibited by state or local codes.

*Aftermarket: Completion of sale, not for purpose of resale, from the manufacturer.
10. Maintain adequate clearances around air openings.
11. Young children should be carefully supervised when they are in the same room as the appliance.
12. Keep appliance area clear and free from combustible materials, gasoline and other flammable vapors and liquids.

WARNING: DO NOT ALLOW CLOTHING OR FLAMMABLE MATERIALS ON OR NEAR THE FIREPLACE.

PRE-INSTALLATION REQUIREMENTS

Combustion and Ventilation Air Requirement Worksheet (Vent Free only)

WARNING: IF THE AREA IN WHICH THE HEATER MAY BE OPERATED IS SMALLER THAN THAT DEFINED AS AN UNCONFINED SPACE OR IF THE BUILDING IS OF UNUSUALLY TIGHT CONSTRUCTION, PROVIDE ADEQUATE COMBUSTION AND VENTILATION AIR BY ONE OF THE METHODS DESCRIBED IN THE NATIONAL FUEL GAS CODE, ANSI Z223.1, SECTION 5.3. OR APPLICABLE LOCAL CODES.

This heater shall not be installed in a confined space or unusually tight construction unless provisions are provided for adequate combustion and ventilation air.

The following formula can be used to determine the maximum BTU rating per the definition of unconfined space:

STEP ONE: DETERMINE THE VOLUME OF SPACE IN CUBIC FEET.

LENGTH X WIDTH X HEIGHT = _____ cu. ft.

(Include adjoining rooms with doorless passageways or ventilation grills between rooms.)

Example: 24' (L) X 16' (W) X 8' (H) = 3,072 cu. ft.

STEP TWO: MULTIPLY THE VOLUME OF SPACE BY 20 BTU/Hr. TO DETERMINE THE MAXIMUM BTU/Hr. THE SPACE CAN SUPPORT.

Example: 3,072 cu. ft. X 20 BTU/Hr. = 61,440 BTU/Hr.
(Maximum BTU/Hr. the room can support)

STEP THREE: ADD THE BTU/Hr. OF ALL THE FUEL BURNING APPLIANCES IN THE SPACE.

VENT-FREE HEATER	_____	BTU/Hr.
GAS APPLIANCE #1	_____	BTU/Hr.
GAS APPLIANCE #2	_____	BTU/Hr.
Total	_____	BTU/Hr.

Example: VENT-FREE HEATER	26,000	BTU/Hr.
GAS APPLIANCE #1	<u>35,000</u>	BTU/Hr.
Total	61,000	

NOTE: DO NOT INCLUDE DIRECT-VENT GAS APPLIANCES.
DIRECT-VENT IS SEALED COMBUSTION AND DRAWS COMBUSTION AIR FROM THE OUTDOORS.

THE SPACE IN THE ABOVE EXAMPLE IS AN UNCONFINED SPACE BECAUSE THE 61,000 BTU'S AN HOUR USAGE IS LESS THAN THE 61,440 BTU'S AN HOUR AVAILABLE. IF THE TOTAL BTU'S AN HOUR USAGE IS GREATER THAN 61,440 BTU'S AN HOUR THEN THE SPACE WOULD BE A CONFINED SPACE AND ADDITIONAL FRESH AIR MUST BE PROVIDED.

The National Fuel Gas Code ANSI Z223.1 defines a confined space as a space whose volume is less than 50 cubic feet per 1,000 Btu per hour (4.8 m³ per kw) of the aggregate input rating of all appliances installed in that space and unconfined space as a space whose volume is not less than 50 cubic feet per 1,000 Btu per hour (4.8 m³ per kw) of the aggregate input rating of all appliances installed in that space. Rooms communicating directly with the space in which the appliances are installed, through openings not furnished with doors, are considered a part of the unconfined space.

INSTALLATION SPECIFICATIONS

BTU Ratings and Pressure Requirements

Log Set Size	18"-21" Sets		24" - 30" Sets	
Gas Type	Natural	Propane	Natural	Propane
Max. Heat Input	27,000 BTU/hr.	25,000 BTU/hr.	40,000 BTU/hr.	30,000 BTU/hr.
Min. Heat Input	20,000 BTU/hr.	19,000 BTU/hr.	25,000 BTU/hr.	22,000 BTU/hr.
Gas Inlet Pressure				
Max.	10.5 ins. WC	13 ins. WC	10.5 ins. WC	13 ins. WC
Min.	4 ins. WC	10 ins. WC	4 ins. WC	10 ins. WC
Regulator Pressure	4 ins. WC	10 ins. WC	4 ins. WC	10 ins. WC

When operating the main burner, use the control knob to raise and lower the min. and max. heat output. Turn the control knob counterclockwise for max. heat and clockwise for min. heat.

Input ratings are shown in BTU per hour and are for elevations up to 2,000 feet. For elevations above 2,000 feet, input ratings should be reduced 4% for each 1,000 feet above sea level. Refer to the National Fuel Gas Code.

WARNING: OPERATION OF THIS APPLIANCE ON GASES FOR WHICH IT IS NOT EQUIPPED MAY LEAD TO CARBON MONOXIDE POISONING.

Fireplace Dimensions and Clearances

Refer to the following charts to determine the proper size set for your fireplace. (Fig.1)

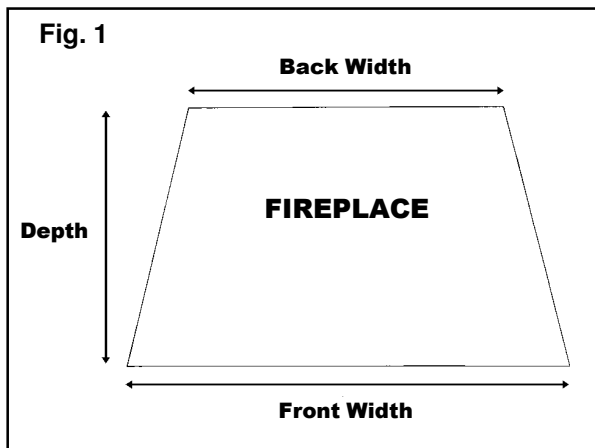

Log Set Size	Fireplace Dimensions			
	Depth	Height	Front Width	Back Width
18"	13"	17"	28"	18"
21"	13"	17"	28"	18"
24"	13"	17"	32"	22"
30"	13"	17"	36"	22"

The chart above indicates the minimum fireplace dimensions for each log set. **The back width is the most critical dimension.** The right side of the unit is the control side.

INSTALLATION SPECIFICATIONS

Minimum Clearances to Combustible Materials (Vent Free only)

IMPORTANT: To insure a safe installation into a masonry or factory built fireplace, the following instructions must be carefully observed. For Fireplace Manufacturers Incorporated (FMI), and Security Fireplace vent free fireplaces, follow the instructions accompanying the fireplace.

Note: Clearances to Combustible Materials (Fig.2) and Mantle Clearances (Fig.3 & 4) are in place to provide adequate spacing to prevent a fireplace mantel or facing from catching fire. In most cases they should also be adequate to prevent any discoloration or warping due to heat. However, each Gas Log installation will present unique circumstances creating many variables beyond the control of the Gas Log Manufacturer, including paint or finish composition, previous heat exposure, quality of construction, air flow patterns etc. Because of these variables we cannot guarantee that heat warping or discoloration will never occur. The possibility of heat damage exists whether burning wood or gas logs.

Refer to Fig.2 for the following dimensions

- A) Minimum left and right clearance to combustible walls = 15".
- B) Minimum clearance to combustible ceiling = 42".
- C) Minimum left and right side clearance to mantle = 6".

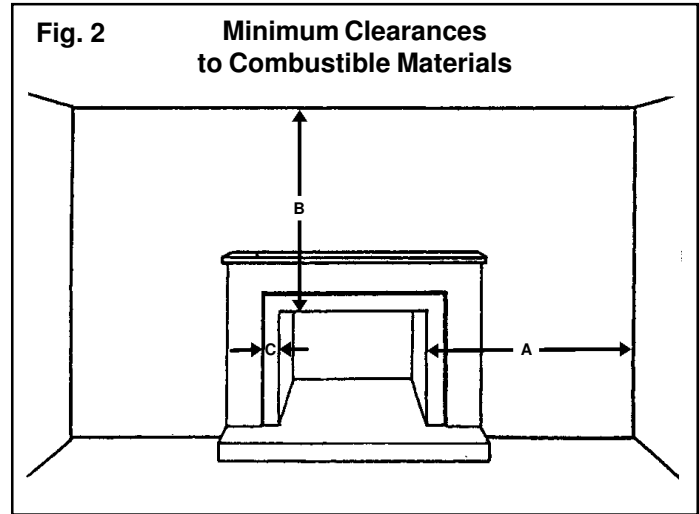

Mantle Clearances (Vent Free only)

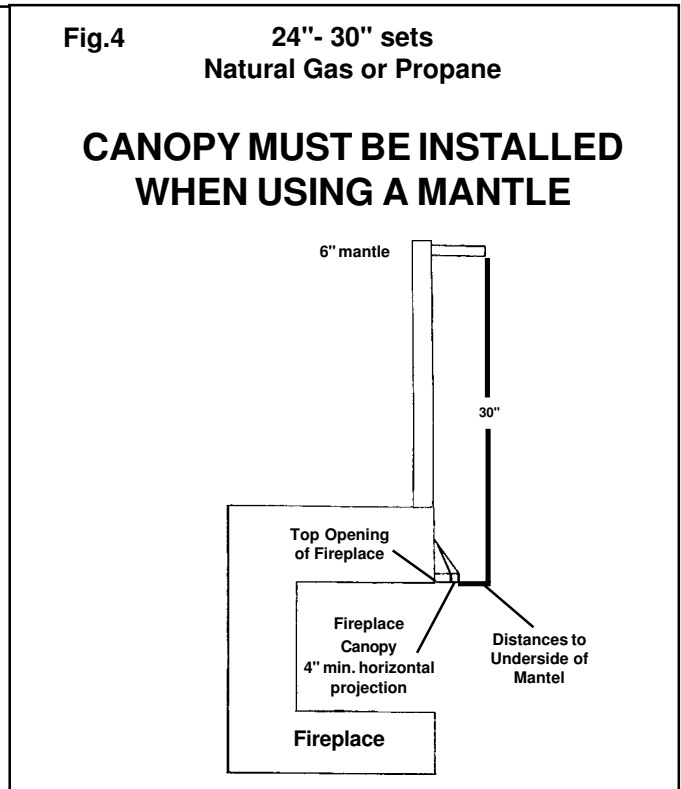
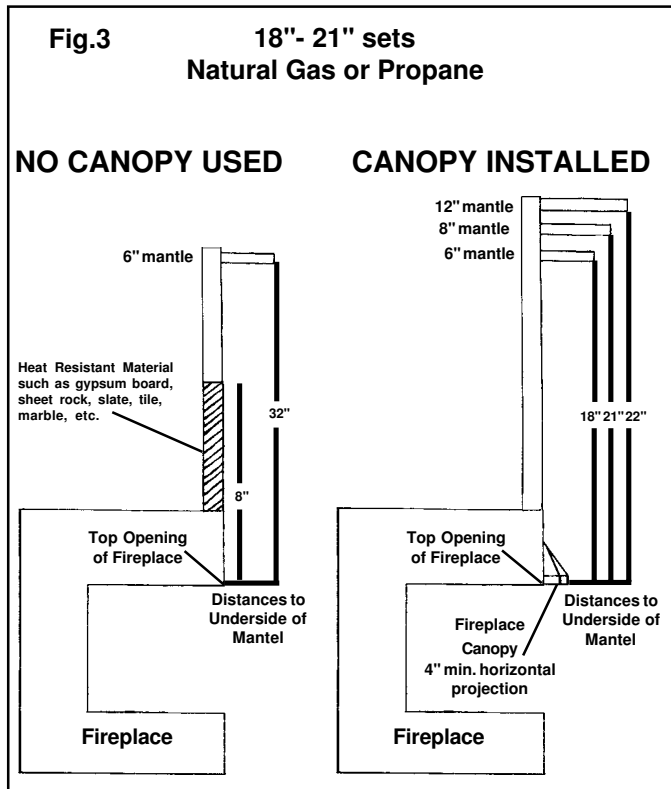

INSTALLATION SPECIFICATIONS

Mantle Clearances cont. (Vent Free only)

Woodwork, such as mantles and other combustible material, must be installed as tested per Fig.3 or Fig.4

If mantel and wall are both non combustible, mantel clearances are not applicable.

NOTE: Heat Resistant Material as shown in Fig.3 are materials such as gypsum board, sheetrock, slate, tile, marble, etc...

FIREPLACE CANOPY

A canopy (as shown in Fig.5) is used to deflect heat away from the fireplace face and mantel, reducing the chances of heat damage or discoloration. If using a canopy, it must project a minimum of 4" from the face of the firebox. Contact your dealer to purchase a fireplace canopy.

INSTALLATION

INSTALLER: Please leave these instructions with the home owner.

OWNER: Please retain these instructions for future reference.

State or local codes may only allow operation of this appliance in a vented application. Check your state and local codes.

IMPORTANT: Read these instructions carefully before installing or trying to operate this vent free gas heater.

All Hargrove vent free room heaters comply with IAS U.S. Requirement 5-95.

"WARNING: ANY MODIFICATION TO THIS UNVENTED GAS HEATER OR ITS CONTROLS CAN BE DANGEROUS." IMPROPER INSTALLATION OR USE OF THE HEATER CAN CAUSE SERIOUS INJURY OR DEATH FROM FIRE, BURNS, EXPLOSION OR CARBON MONOXIDE POISONING.

The installation must conform with local codes or, in absence of local codes, with the National Fuel Code, ANSI Z223.1.

"WARNING: GLASS DOORS MUST BE OPEN WHEN THE APPLIANCE IS IN OPERATION.

FIREPLACE PREPARATION

IMPORTANT: Before installing in a solid fuel burning fireplace, the chimney flue and firebox must be cleaned of soot, creosote, ashes, and loose paint by a qualified chimney cleaner.

1. Turn the gas supply **OFF**.
2. Turn **OFF** all electrical power to blower (if applicable) before installing, servicing, or removing.
3. Clean the fireplace floor, walls, and chimney (if used) of any ashes, soot, creosote, or obstruction. *This will minimize any smell from the fireplace.* We recommend cleaning by a chimney sweep.
4. Any outside air ducts and/or ash dumps in the fireplace must be permanently closed at the time of appliance installation.
5. A mesh fireplace screen must be in place when the appliance is operating unless other provisions for combustion air are provided, the screen shall have an opening(s) for introduction of combustion air.

DAMPER STOP (Vented sets only)

Attach the damper stop clamp to the fireplace damper blade. Position the clamp to prevent full closure of the fireplace damper blade.

If the damper stop provided does not fit, the installer shall install a permanent damper stop that will keep the damper open to a minimum opening.

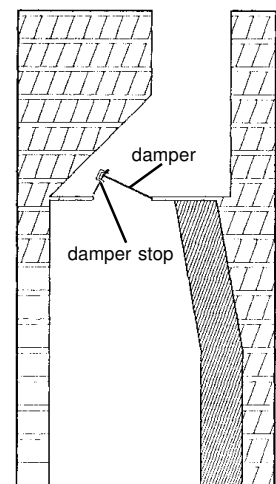

INSTALLATION

GAS LINE HOOK-UP

NOTE: Before you proceed, make sure your gas supply is **OFF!**

WARNING: OPERATION OF THIS APPLIANCE ON GASES FOR WHICH IT IS NOT EQUIPPED MAY LEAD TO CARBON MONOXIDE POISONING.

IMPORTANT: This appliance cannot be used with or converted to a gas other than the type for which it was equipped at the factory.

Check Gas Type: The gas supply must be the same as stated on the heater's rating plate. If the gas supply is different, **DO NOT INSTALL** the heater. Contact your dealer for the correct model.

WARNING: DO NOT USE A BLOWER INSERT, HEAT EXCHANGER INSERT OR OTHER ACCESSORY NOT APPROVED FOR USE WITH THIS HEATER.

IMPORTANT STEPS TO FOLLOW WHEN MAKING THE GAS LINE HOOK-UP (Fig.5)

1. Consult your gas supplier for proper gas pipe sizing. Normally up to 50' of 1/2" inside diameter (ID) gas pipe will supply adequate volume for all vent free units.

2. The incoming gas line may be routed into the fireplace either from the left or right side.

3. Include a manual shutoff valve in the gas supply line so the appliance may be disconnected for servicing.

4. Center the burner system from side to side in the firebox. In a vented firebox, if the damper is used, the burner assembly should be located directly under the damper.

5. Use the 3/8" aluminum connector (provided in the accessory kit) to connect the gas supply line to the inlet connection on the Millivolt Gas Valve.

6. Always use an external regulator for all L.P. appliances to reduce the supply tank pressure to a maximum of 13" W.C. This is in addition to the internal regulator on the Millivolt Gas Valve.

WARNING: CONNECTING DIRECTLY TO AN UNREGULATED L.P. TANK CAN CAUSE AN EXPLOSION.

7. Test all connections after turning gas supply on for leaks using a soap and water solution. **DO NOT USE AN OPEN FLAME FOR LEAK TESTING.**

8. It is most convenient to light the pilot and check the operation of the main burner with the logs not in place. After completing the following section (Wiring Schematic) and carefully checking the gas supply line for leaks and correcting any found, refer to the "LIGHTING INSTRUCTIONS" section (pg.10) to test the burner assembly.

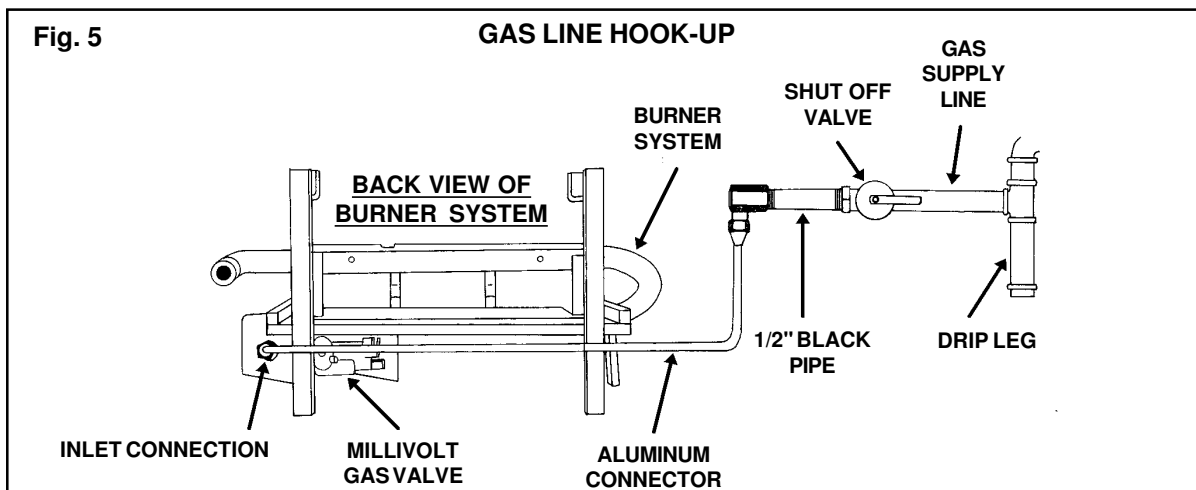

INSTALLATION

Wiring Schematic (Fig. 6)

CAUTION: Label all wires prior to disconnection when servicing controls. Wiring errors can cause improper and dangerous operation. Verify proper operation after servicing.

NOTE: When testing the burner system a jumper wire can be placed on the two outside terminals labeled "TH". This will allow the main burner to be lit without use of the Wall Switch or other optional items. **Remove the jumper wire before installing optional items. (Fig.6)**

WALL SWITCH

1. To install the wall switch mount a 3" X 2" electrical box in the wall near the fireplace. Run the thermostat wire (18 gauge wire supplied in accessory kit) from the electrical box to the millivolt valve.
2. At the valve connect the lead wires to the two outside terminals labeled "TH".
3. On the Wall Switch connect a lead wire to each terminal.
4. Mount the wall switch to the electrical box and install the cover plate.
*If installing a remote control, thermostat, or timer, attach the the leads from the optional item to the same terminals as the Wall Switch on the Millivolt Valve.

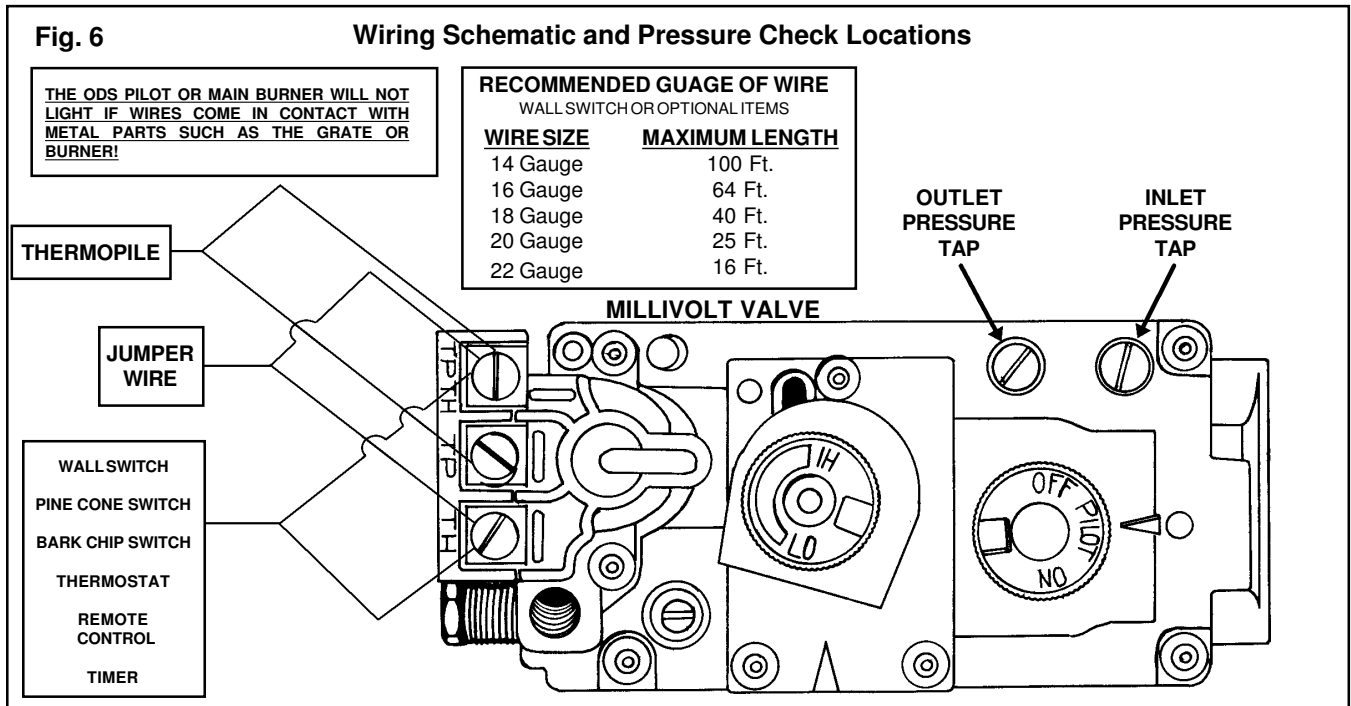

Gas Pressure Check (Fig. 6)

NOTE: The appliance and it's individual shut off valve must be disconnected from the gas supply system during any pressure testing of that system at test pressures in excess of 0.5 psig (3.5 kPa). The appliance must be isolated from the gas supply piping system by closing its individual manual shut off valve during any pressure testing of the gas supply piping system at test pressures equal to or less than 0.5 psig (3.5 kPa).

1. The pressure should be checked with the heater

burning and the control set to high (HI).

2. Inlet pressure can be checked by turning captured screw labeled E on the valve clockwise 2 or 3 turns and then placing tubing over test point. Outlet pressure (Regulator Pressure) can be checked in the same manner above using the captured screw labeled A.

**If the pressure is not as specified in "BTU Rating and Pressure Requirements" (pg. 3), contact your dealer.*

IMPORTANT: After taking pressure readings, be sure to turn captured screws clockwise firmly to reseal. Do not over torque.

INSTALLATION

Log Placement

Follow the steps listed for the proper positioning of each log. (Fig.7)

1. Find your "LOG ASSEMBLY DIAGRAM" page in the carton with your logs. Locate your log set on this page
2. The largest log in the carton is the Front Log. Center the Front Log on the grate with the flat unfinished side vertical, facing toward the back. Align the cut-outs on the bottom of the log with the grate supports.
3. The second largest log in the carton is the Back Log. Center the Back Log on the top pedestal with the flat

side facing down. Align the cut-outs on the log with the bracket on the back of the pedestal.

4. The remaining logs are the top logs. They should be placed in the grooves on the Front Log and the Back Log. Use your "LOG ASSEMBLY DIAGRAM" to guide you in the correct placement of each log.

IMPORTANT: The logs require to be carefully positioned as shown, for proper operation. **Flame impingement will cause sooting and carbon monoxide.** If the flame comes in contact with the top logs when the main burner is on, the logs are incorrectly placed. The logs should be moved away from the flame so impingement does not occur.

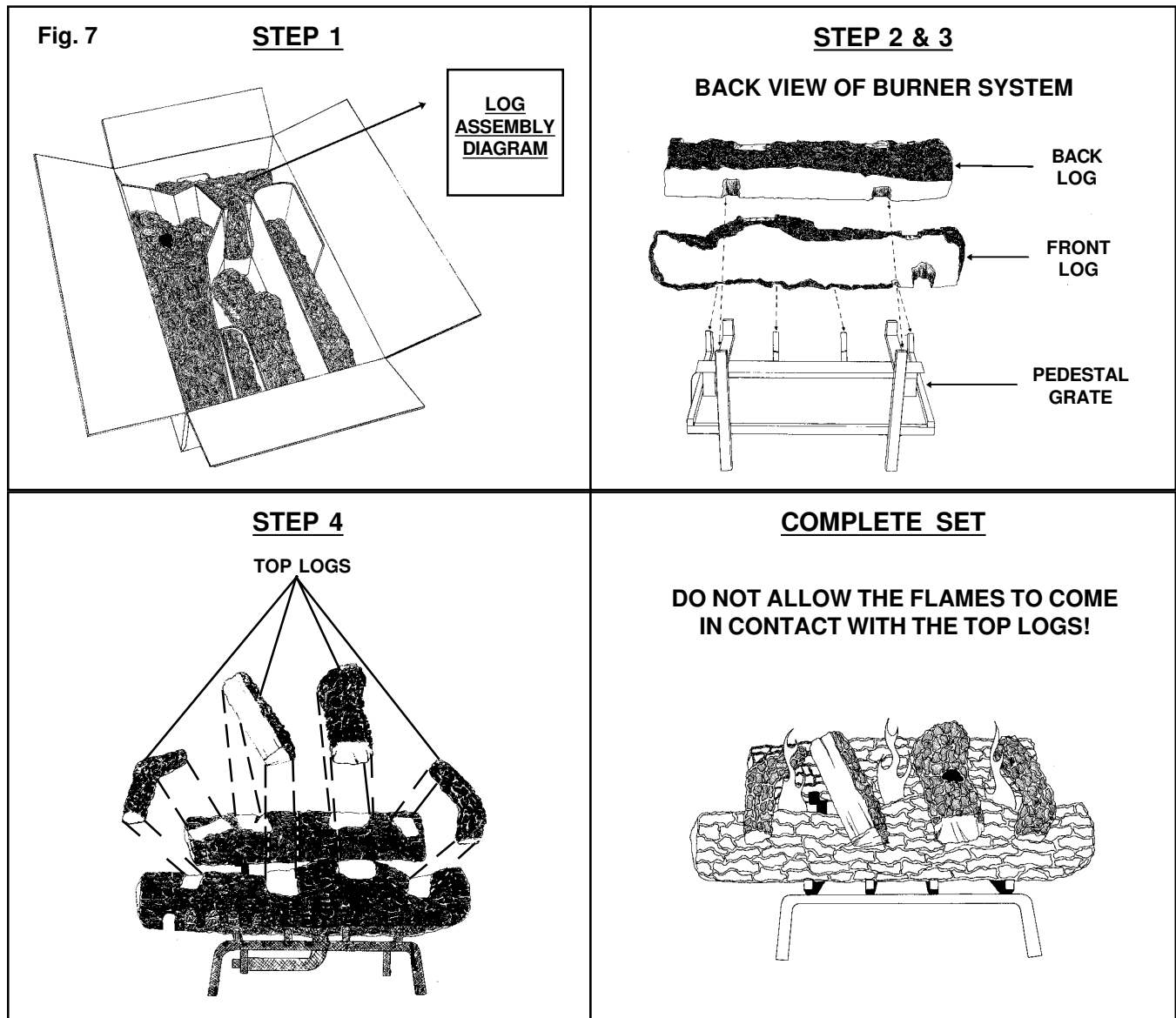

INSTALLATION

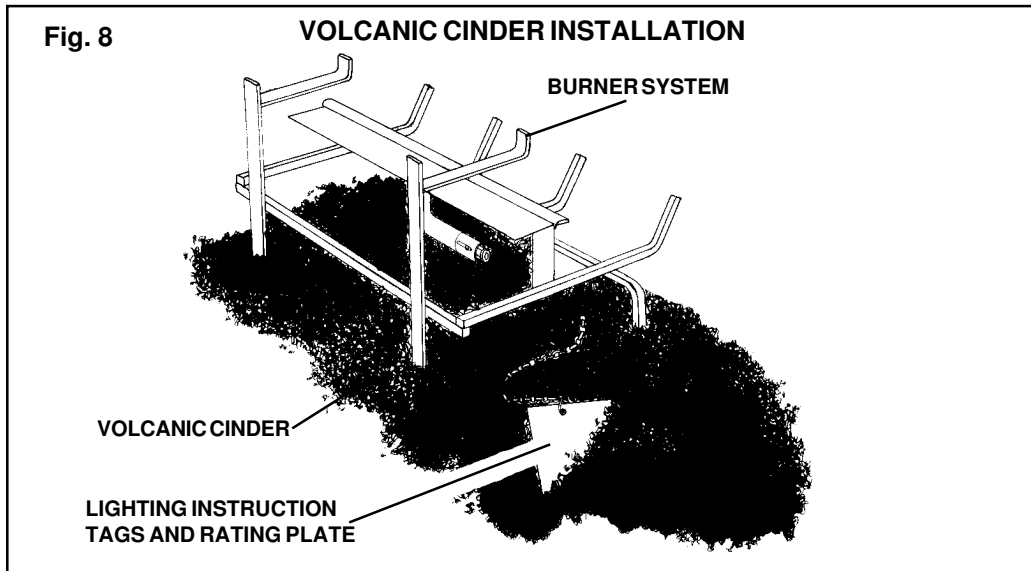

Volcanic Cinder

The Volcanic Cinder is the large bag of black rock that is supplied in the accessory kit. Pour the Volcanic Cinder on the floor of the fireplace around and under the burner system. (Fig.8)

SUGGESTION: The Volcanic Cinder can be used to cover up the "LIGHTING INSTRUCTION" tags and "Rating Plate". **DO NOT** detach these tags. This will void the manufacturers warranty.

WARNING: **DO NOT** pour the Volcanic Cinder on the burner system or around the pilot.

Optional Pedestal Grate Facing

Secure the Pedestal Grate Facing to the outer tines on the Pedestal Grate by placing the hangers (A) over the top of the tines. (Fig.9)

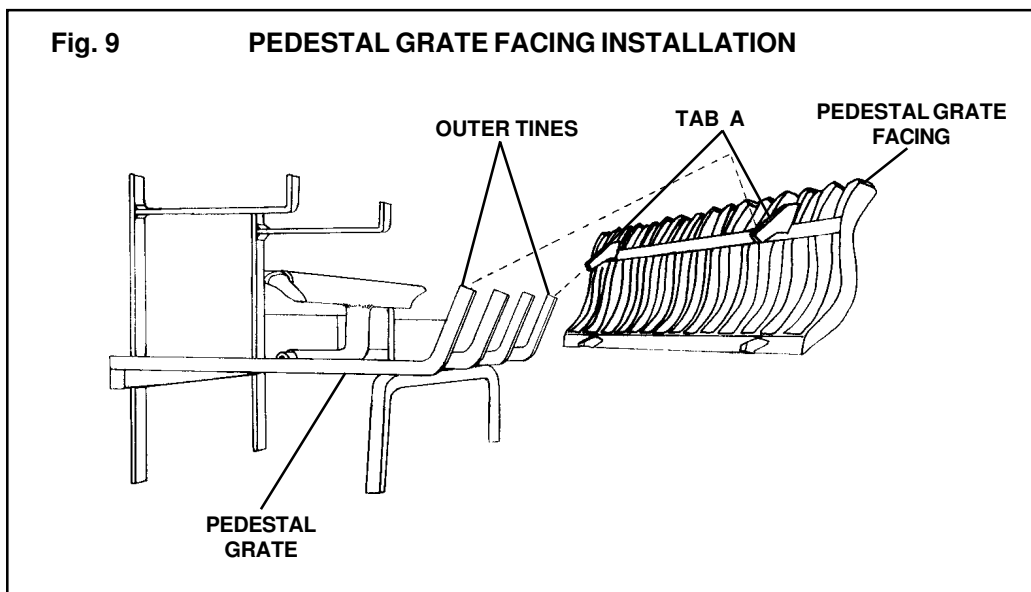

OPERATION

FOR YOUR SAFETY READ BEFORE LIGHTING

- A. This appliance has a pilot which is lit by a spark ignitor system. When lighting the pilot, follow these instructions exactly.
- B. BEFORE LIGHTING smell all around the appliance area for gas. Be sure to smell next to the floor because some gas is heavier than air and will settle on the floor.

WHAT TO DO IF YOU SMELL GAS:



- * Do not try to light any appliance.
- * Do not touch any electric switch; do not use any phone in your building.
- * Immediately call your gas supplier from a neighbor's phone. Follow the gas supplier's instructions.
- * If you cannot reach your gas supplier, call the fire department.

WARNING: If you do not follow these instructions exactly, a fire or explosion may result causing property damage, personal injury or loss of life.

- C. Use only your hand to push in or turn the gas control knob. Never use tools. If the knob will not push in or turn by hand, don't try to repair it, call a qualified service technician. Force or attempt repair may result in a fire or explosion and may void your warranty.
- D. Do not use this appliance if any part has been under water. Immediately call a qualified service technician to inspect the appliance and to replace any part of the control system and any gas control which has been under water.

LIGHTING INSTRUCTIONS

WARNING: At no time should the "LIGHTING INSTRUCTION" tags be detached from the burner system. Removing the tags will void the manufacturer's warranty.

1. **STOP!** Read the safety information above on this label.
2. Turn off all electrical power in firebox before installing.
3. Depress the control knob and turn clockwise  as far as it will go to reach the "OFF" position.
4. Wait five (5) minutes to clear out any gas. Then smell for gas, including near the floor. If you smell gas, **STOP!** Follow 'B' in the safety information above on this label. If you don't smell gas, go to next step.
5. Depress the control knob and turn counterclockwise  to the "PILOT" position.

GAS CONTROL

Fig. 10

Control Knob

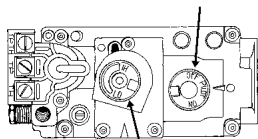

Flame Height Control Knob

6. Push in control knob *all the way* and hold in.
 - * If the control knob is not held in all the way the pilot will not stay lit when the knob is released.
 - * Do not turn the knob when pushing it in.
7. Light the pilot (mounted in front of the main burner) by pushing the spark ignitor button several times. This will cause a spark at the pilot which will ignite the pilot gas. If the spark does not work, light the pilot with a match.
 - * When lighting the pilot it may take several seconds for gas to reach the pilot.
8. Continue to hold the control knob in *all the way* for about 30 seconds after the pilot is lit.
9. Release the knob and it will pop back out. The pilot should remain lit. If it goes out, repeat steps 3 through 9.
 - * If knob does not pop up when released, stop and immediately call your service technician or gas supplier.

7. Depress the control knob counterclockwise  to "ON". Turn flame height control knob counterclockwise to select desired comfort level.

IMPORTANT: The gas control has an interlock device. *After shutting off all gas flow, the pilot burner cannot be relit until the thermocouple has cooled, allowing the electromagnet to be released (approx. 60 sec.).* The gas control knob is designed to be operated by hand. DO NOT use any tools during this operation. Damaged knobs may result in serious injury.

NOTE: A periodic visual check of the pilot flames (Figure 11) and main burner flames (Figure 12) should be made. The pilot flame should always be present when the appliance is in operation. See illustrations below.

Fig. 11

NATURAL GAS
ODS PILOT

LIQUID PROPANE
ODS PILOT

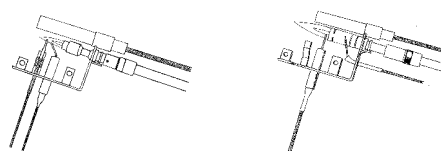

WARNING: TAMPERING WITH THE ODS PILOT WILL VOID THE MANUFACTURER'S WARRANTY.

Fig. 12

MAIN BURNER

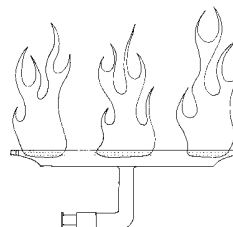

OPERATION

TO TURN OFF GAS TO APPLIANCE

TEMPORARY SHUTDOWN PROCEDURE: To turn off main burner only, depress the knob and turn it clockwise  as far as it will go. Do not force.

COMPLETE SHUT-DOWN PROCEDURE: Turn off all electrical power in firebox. Turn gas control knob clockwise to "OFF" position.

Controlling Heat Output

* The heat output can be controlled by the vent free burner control knob.

* In a vented fireplace the heat output can also be controlled by the position of the flue damper.

- **The damper setting should be fully closed for maximum heat output, partially closed for less heat output, and fully open for minimum heat output.**

-Some jurisdictions will not allow the damper to be opened.-

Important Safeguards

1. To avoid personal injury, do not touch hot surfaces when the appliance is operating. Touch only the piezo ignitor and control knob.

Hot Surfaces

- Grate
- Burner
- Logs
- Surfaces above the opening of the fireplace

2. Although your gas logs are very realistic in appearance, it is not a real wood-burning fireplace and must not be used for burning any material.

* To avoid irreparable damage to the appliance or personal injury, matches, paper, garbage, or any other material must not be placed or thrown on top of the logs or into the flames.

3. Close supervision is necessary when the appliance is being operated near children.

4. Avoid any drafts that alter burner patterns. Do not allow fans to blow directly into the fireplace. Ceiling fans may create drafts that alter burner flame patterns. Sooting and improper burning will occur.

Cleaning and Servicing

Installation and repair should be done by a qualified service person. The appliance should be inspected before use and at least annually by a professional service person. More frequent cleaning may be required due to excessive lint from carpeting, bedding material, etc. It is imperative that control components, burners and circulating air passageways of the appliance be kept clean.

* If the flames show any unusual shapes or behavior, or the burners fail to ignite properly, then the burner holes may require cleaning.

WARNING: TURN OFF VENT FREE BURNER SYSTEM AND ALLOW TO COOL BEFORE CLEANING OR SERVICING.

Monthly Cleaning

- If removing logs, when reinstalling, refer to "Log Assembly Diagram" for correct log placement.
- Do not use cleaning fluids to clean logs or any part of the heater.
- Brush logs with a soft bristle brush or vacuum with brush attachment.
- Vacuum loose particles and dust from the front and rear burner ports, gas control, piezo cover, and grate.
- Inspect and clean ODS pilot for operation and accumulation of lint at air intake holes.
- Verify flame pattern and log placement for proper operation.
- Verify smooth and responsive ignition of main burner and rear burner. Refer to page 10 for pictorial sketch of proper operation.

Remove Lint or Particles

Annual Cleaning and Inspection

- Dealer or qualified inspector - follow the above steps for proper servicing and inspection.

PARTS IDENTIFICATION

(see drawing on page 13)

PART NAME (SUB ASSEMBLY)	18"-21" SETS		24"-30" SETS	
	Natural Gas	Propane Gas	Natural Gas	Propane Gas
1. Millivolt - Pedestal Grate and Single Burner Tube	MLPGSBT-18	MLPGSBT-18	MLPGSBT-24	MLPGSBT-24
2. Burner Orifice Assembly - Millivolt	BOAML-18-NG	BOAML-18-LP	BOAML-24-NG	BOAML-24-LP
3. Aluminum Connector (for burner assembly)	AC 3/8 *15	AC 3/8 *15	AC 3/8 *18	AC 3/8 *18
4. Single Burner Millivolt Gas Valve Assembly	SBMGVA-18-NG	SBMGVA-18-LP	SBMGVA-24-NG	SBMGVA-24-LP
5. Oxygen Depletion System Millivolt Assembly	ODSMLA-NG	ODSMLA-LP	ODSMLA-NG	ODSMLA-LP
6. Pedestal Grate Facing (optional)	PGF-18	PGF-18	PGF-24	PGF-24
7. Aluminum Connector	AC-18	AC-18	AC-18	AC-18
8. Gas Fire Logs (not pictured)	(5) Logs	(5) Logs	(6) Logs	(6) Logs
9. Bell Wire - 20'	BW-20	BW-20	BW-20	BW-20
10. Wall Switch	WS	WS	WS	WS
11. Thermostat (optional item)	TST	TST	TST	TST
12. Remote Control 110V (optional item)	RC 110V	RC 110V	RC 110V	RC 110V
13. Remote Control 12V (optional item)	RC 12V	RC 12V	RC 12V	RC 12V
14. Timer (optional item)	TIME	TIME	TIME	TIME
15. Bark Chip Switch (optional item - not pictured)	BCS	BCS	BCS	BCS
16. Pine Cone Switch (optional item)	PCS	PCS	PCS	PCS

WARNING: Failure to position the parts in accordance with these diagrams or failure to use only parts specifically approved with this heater may result in property damage or personal injury.

Vent Free Burner Assembly
Pedestal Grate Facing not shown

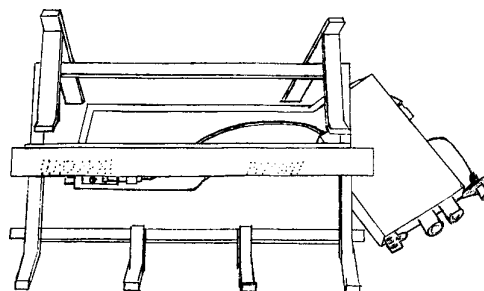

ASSEMBLY IDENTIFICATION

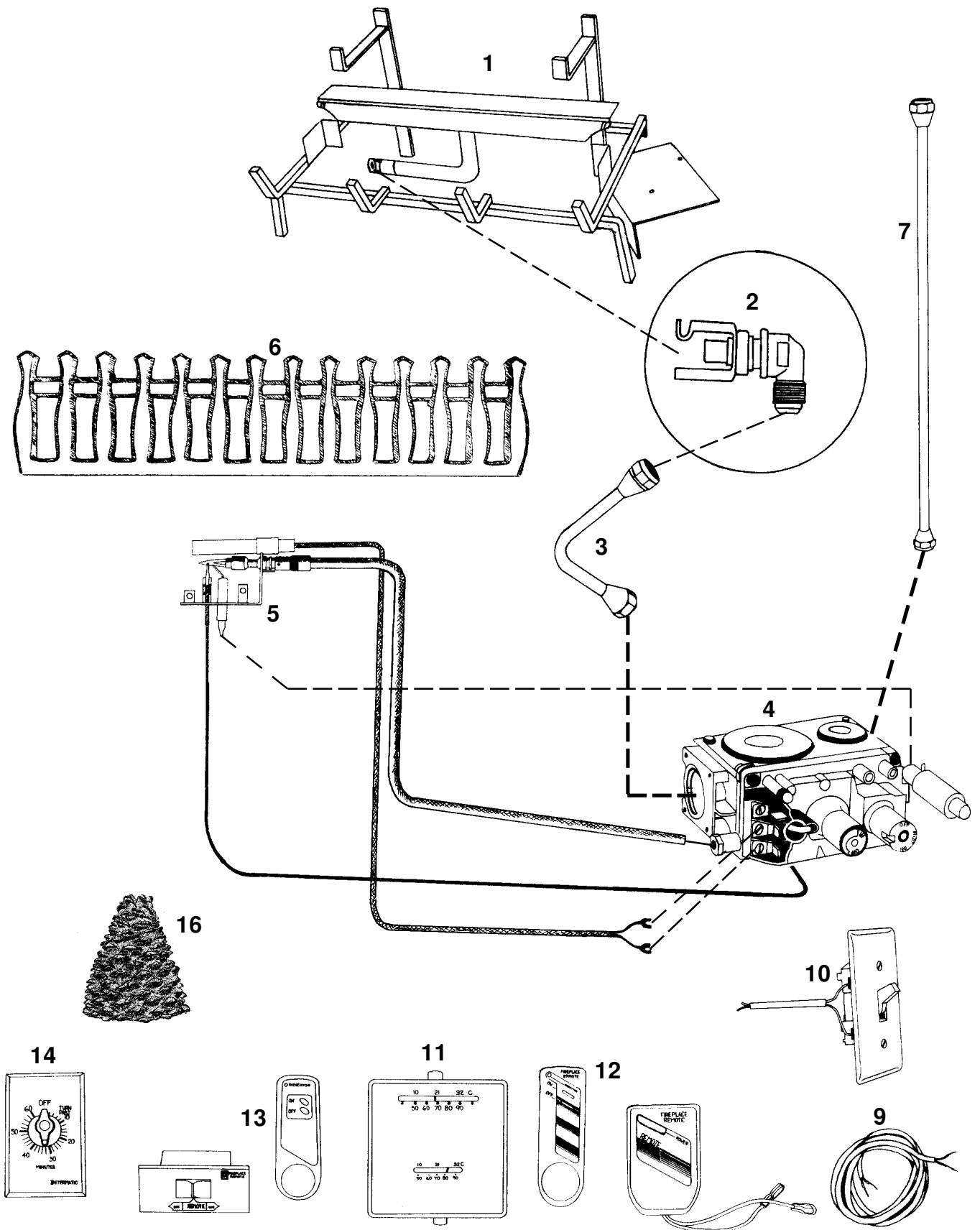

TROUBLE-SHOOTING

Hargrove Manufacturing test fires all Vent Free burner systems before shipment. Each test consists of lighting the pilot, checking for proper ignition, and leak testing at each connection. Even though all of these precautions are taken sometimes problems do arise. The following Trouble-Shooting chart lists several problems with their probable cause and remedy.

WARNING: TURN OFF AND LET COOL BEFORE SERVICING. ONLY A QUALIFIED SERVICE PERSON SHOULD SERVICE AND REPAIR.

<u>OBSERVED PROBLEM</u>	<u>POSSIBLE CAUSE</u>	<u>REMEDY</u>
<i>A. When ignitor button is pressed there is no spark at the ODS pilot.</i>	<ol style="list-style-type: none"> 1. Ignitor electrode positioned wrong. 2. Ignitor electrode is broken. 3. Ignitor electrode is not connected to ignitor cable. 4. Ignitor cable is pinched. 5. Ignitor cable is wet. 6. Broken ignitor cable. 7. Bad Piezo ignitor. 	<ol style="list-style-type: none"> 1. Replace ignitor. 2. Replace ignitor. 3. Reconnect ignitor cable. 4. Free ignitor cable if pinched by any metal or tubing. 5. Dry ignitor cable. 6. Replace ignitor cable. 7. Replace Piezo ignitor.
<i>B. ODS pilot lights, but flame goes out when control knob is released.</i>	<ol style="list-style-type: none"> 1. Control knob not fully depressed. 2. Control knob not pressed in long enough. 3. Manual shutoff valve not fully open. 4. Thermocouple connection loose at valve. 5. Pilot flame not touching thermocouple, which allows thermocouple to cool, causing pilot flame to go out. This problem could be caused by one or both of the following: A) Low gas pressure. B) Dirty or partially clogged ODS pilot. 6. Thermocouple damage. 7. Control valve damage. 	<ol style="list-style-type: none"> 1. Press in control knob fully. 2. After ODS pilot lights, keep control knob pressed in 30 seconds. 3. Fully open manual shutoff valve. 4. Hand tighten until snug, then tighten 1/4 turn more. 5. Contact local gas company. 6. Replace ODS pilot. 7. Replace control valve.
<i>C. Appliance shuts off in use.</i>	<ol style="list-style-type: none"> 1. Not enough fresh air is available for ODS pilot to operate. 2. Low gas pressure 3. ODS pilot is partially clogged. 4. Unstable pilot flame due to drafts from ceiling fan, hot furnace register, open door etc... 5. If using damper, unstable pilot flame from downdrafts. 	<ol style="list-style-type: none"> 1. Open door to adjoining room for added ventilation or open window. 2. Contact local gas company. 3. Clean ODS pilot. 4. Locate and eliminate drafts. 5. Close damper.

TROUBLE-SHOOTING

<u>OBSERVED PROBLEM</u>	<u>POSSIBLE CAUSE</u>	<u>REMEDY</u>
<i>D. When ignitor button is pressed, there is spark at ODS pilot, but no ignition.</i>	<ol style="list-style-type: none"> 1. Gas supply turned off or manual shutoff valve closed. 2. Control knob not in PILOT position. 3. Control knob not pressed in while in PILOT position. 4. Air in gas line. 5. ODS pilot is clogged. 	<ol style="list-style-type: none"> 1. Turn on gas supply or open manual shutoff valve. 2. Turn control knob to PILOT position then depress knob. 3. Press in control knob while in PILOT position. 4. Continue holding down control knob. Repeat igniting operation until air is removed. 5. Clean ODS pilot.
<i>E. Gas odor even when control knob is in OFF position.</i>	<ol style="list-style-type: none"> 1. Gas leak. 2. Control valve defective. 	<ol style="list-style-type: none"> 1. Locate and correct all leaks. 2. Contact dealer to receive further instructions on correcting problem.
<i>F. Slight odor during initial operation.</i>	<ol style="list-style-type: none"> 1. Smell coming from the paint curing on the logs and burner system. 	<ol style="list-style-type: none"> 1. Problem will stop after a few hours of operation. Run the heater with the damper open if you have one or open a window for the first few hours.
<i>G. Main burner does not light after ODS pilot is lit.</i>	<ol style="list-style-type: none"> 1. Burner orifice is clogged. 2. Inlet gas pressure is too low. 3. Gas line obstruction.(pipe dope, teflon tape, etc...) 	<ol style="list-style-type: none"> 1. Clean burner orifice and main burner. 2. Contact local gas company. 3. Locate and clear obstruction.
<i>H. Delayed ignition of main burner.</i>	<ol style="list-style-type: none"> 1. Burner orifice is clogged. 2. Inlet gas pressure is too low. 3. Gas line obstruction. (pipe dope, teflon tape, etc...) 	<ol style="list-style-type: none"> 1. Clean burner orifice and main burner. 2. Contact local gas company. 3. Locate and clear obstruction.
<i>I. Main burner backfiring during combustion.</i>	<ol style="list-style-type: none"> 1. Burner orifice is clogged or damaged. 2. Inlet gas pressure is too low. 3. Gas line obstruction. (pipe dope, teflon tape, etc...) 	<ol style="list-style-type: none"> 1. Clean or replace burner orifice. Clean main burner. 2. Contact local gas company. 3. Gas line obstruction. (pipe dope, teflon tape, etc...)
<i>J. Appliance produces unwanted odors.</i>	<ol style="list-style-type: none"> 1. Appliance is burning vapors from paint, new carpet, hair spray, perfume, pet hair, glues, etc... 2. Gas leak. 	<ol style="list-style-type: none"> 1. Ventilate room. Stop using odor-causing products while heater is running. 2. Locate and correct all leaks.
<i>K. Soot is depositing on logs, in the fireplace, or in room.</i>	<ol style="list-style-type: none"> 1. Flames from main burner are coming in contact with the logs. 2. Lint or particles have deposited on the main burner 	<ol style="list-style-type: none"> 1. Logs must be repositioned so they do not come in contact with the flame. 2. Clean main burner.

LIMITED WARRANTY

Refractory Logs

Hargrove gas logs carry a limited lifetime warranty against any manufactured defect or breakage when installed indoors. A replacement will be available from the dealer at which the appliance was purchased. This warranty does not cover breakage caused by excessive handling once installed and fired. Outdoor applications carry a one (1) year limited warranty.

Burner & Grate

If the burner or grate fails due to deterioration within two (2) years of the verified purchase date, a free replacement will be made available from the dealer at which the appliance was purchased.

Valves, Remote Controls, & Switching Devices

Hargrove warrants all valves, remote controls and switching devices against manufacturing defects, which appear within two (2) years of the verified purchase date. Warranty does not cover products that have been damaged by misuse from overheating. Before any product is returned a Return Goods Authorization number (RGA) must be issued by Hargrove's Customer Service Department. All returns must be accompanied by an explanation of the problem and all necessary parts.

All Other Parts

If any assembled part should fail to operate or be found defective which appear within two (2) years of the verified purchase date, a replacement will be available from the dealer at which the appliance was purchased.

Buyer shall notify Hargrove Mfg Corp. of any defect covered by this warranty no later than thirty (30) days after defect is discovered. Failure to provide notice within thirty (30) days shall void the limited warranty.

WHAT IS NOT COVERED

1. Removal and reinstallation costs.
2. Labor costs for replacement or repairs.
3. Transportation or shipping cost.
4. The cost of a service call to diagnose trouble.
5. Painted Surfaces.
6. Damage or defect caused by improper installation, accident, misuse, abuse, alteration, or authorized service technician.
7. Replacement of burner or combustion chamber resulting from improper storage of the appliance.

LIMITATIONS AND EXCLUSIONS

1. No one has authority to add to or vary this limited warranty, or to create for Hargrove Manufacturing Corporation any other obligation or liability in connection with this appliance.
2. Any implied warranty applicable to this appliance is limited in duration to the same period of time as this written Warranty. Some states do not allow limitations on how long an implied warranty lasts, so the above limitations may not apply to you.
3. HARGROVE MANUFACTURING CORPORATION WILL NOT BE LIABLE FOR INCIDENTAL, CONSEQUENTIAL, SPECIAL OR CONTINGENT DAMAGES YOU MIGHT SUFFER AS A RESULT OF A CLAIM UNDER THIS WRITTEN WARRANTY OR ANY IMPLIED WARRANTY. Some states do not allow the exclusion or limitation of incidental or consequential damages, so the above limitations or exclusion may not apply to you.
4. This warranty applies only to the original purchaser and may not be transferred or assigned.
5. If you cannot verify the purchase date of the appliance, the warranty period will begin on the date of which the appliance was manufactured.
6. Replacement or repair parts are warranted for the remaining period of the original part warranty. Warranty parts must be obtained through authorized dealers of this product who will provide original factory replacement parts. Failure to use original factory replacement parts voids this warranty.
7. The maximum liability of Hargrove Mfg Corp. in connection with this limited warranty shall not in any case exceed the contract price paid for the product claimed to be defective or unsuitable.
8. Purchaser or user agrees to hold Hargrove Mfg Corp. harmless from any and all claims by the buyer as a result of injury or damage to an ultimate user or other person caused by the product sold herein by the seller to the buyer, whether the injury or damage results from the assembly, installation, operation, shipment, storage, or manufacture of this product. Hargrove Mfg Corp. makes no warranties, expressed or implied, other than those expressly stated herein.

YOUR DUTIES

This appliance must be installed by a qualified installer, operated and maintained in accordance with all applicable codes and the instructions furnished with the appliance. You must provide a receipt verifying the purchase date of the appliance when making a warranty claim with the dealer from which the appliance was purchased.

This warranty gives you specific legal rights, and you may also have other rights, which vary from state to state.

To register your Hargrove product, please visit our website at <http://www.hargrovegaslogs.com/reg.htm>.

CONTACT INFO: Hargrove Manufacturing Corp.

Tele: (800) 725-4166